

TRES900S Quick Start Guide

Power Requirements

The Reader needs be powered from a +5volt DC (1.8A @ 5V **use the supplied power supply**) power source. The positive power and the ground connections are applied to the Reader at the terminal strip (located inside the reader). The diagram below should assist you with connecting the new TRES900S. Check that the **RED** and **BLACK** wires are installed correctly to our supplied power supply, the **warranty** is based on its use.

Wiring Guide

Selecting the correct size and type of wire will enhance the performance and reliability of your system. The size of the wire must be large enough to carry the maximum current expected without undue voltage losses.

TRES900S Wiring Description

The TRES900S is now terminated inside the reader, thus elimination the pigtail. The diagram below will help you with wiring up the new TRES900S to your selected control panel or other controlling device. As you can see in the below diagram, you have trigger functionality (reader sleeps until triggered, low power consumption), internal relay, RS485 (if using multiple readers or OSDP), RS232 connectivity, an external LED (presently used for the LED bar on the face of the Reader) and multiple earth ground terminations for your convenience.

POWER	WIRE GAUGE									
W(VA)/Amps	8awg	10awg	12awg	14awg	16awg	18awg	20awg	22awg	24awg	26awg
20W/1.67A	559	359	226	142	89	56	35	22	14	9

TRES900S Wiring Diagram

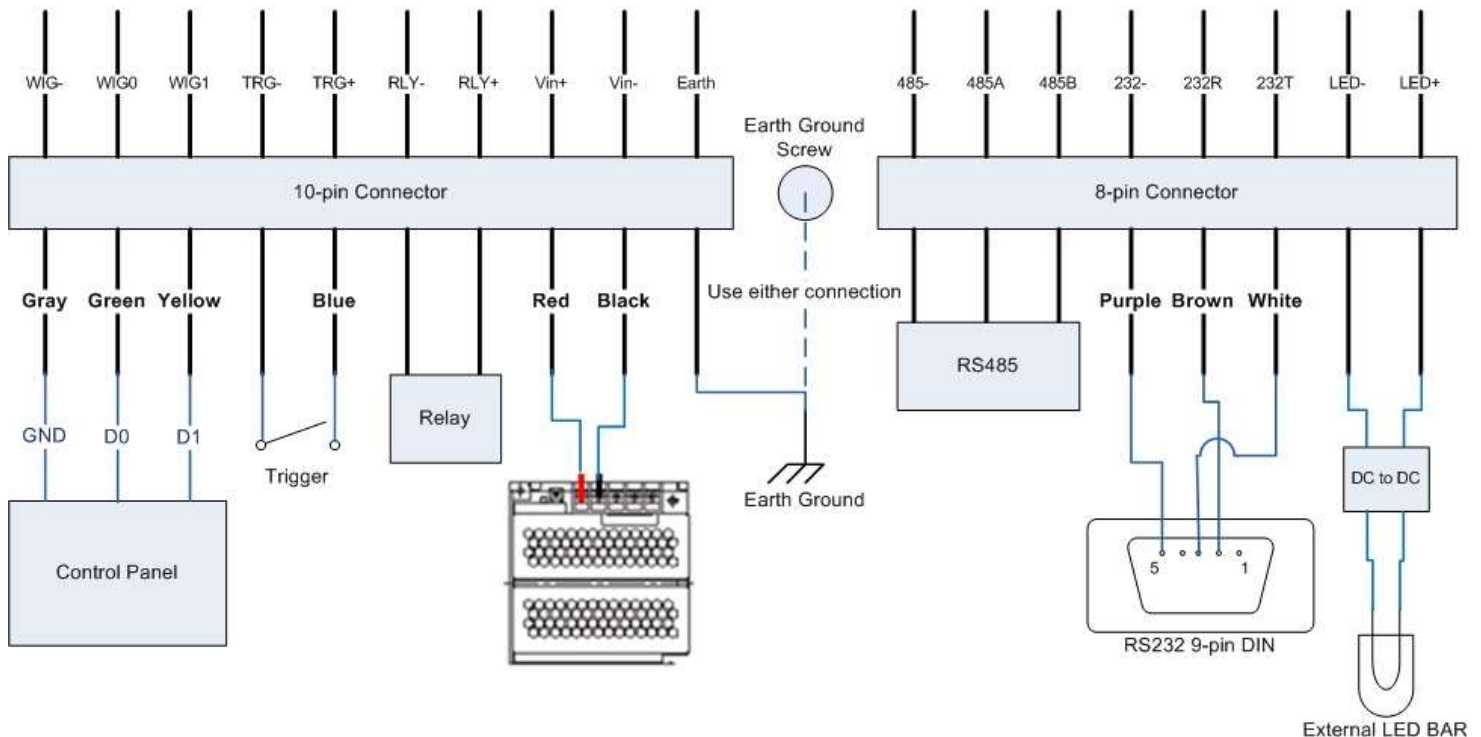

TRES900S UHF Tag Mounting Instructions

It is imperative that these mounting instructions be followed to insure proper performance of the TRES900S Reader. Failure to follow these instructions may result in poor performance.



WS421G + C + W + VIPER – Windshield Stickers

The WS421 series tags are designed to be mounted in a **vertical** orientation on the **inside** of the vehicle's windshield. This tag is tuned to the dielectric properties of the windshields glass so proper performance is achieved when adhered to the windshields glass. Testing is recommended and can be accomplished by taping (painters' tape is recommended) the tag on a temporary basis only. The WS421 must be mounted at least two inches from the metal support posts on either side/bottom of the windshield. The preferred placement is at the bottom/left (driver's side) of the windshield to avoid antennas or tinting at the top of the windshield and to also ensure that the driver's view of the roadway is not obstructed! This mounting position is always recommended when the Reader is positioned on the left side of the travel lane... If the Reader is mounted on the right side of the travel lane, this tag mounting position can be duplicated on the right (passenger) side of the windshield.



WS421-C
center mount at base of
rear view mirror post

Center Mounting the tag at the bottom of the rear-view mirror post works nicely when the Readers are mounted directly overhead in the center of the lane. This is also the recommended position when a combination of Windshield Stickers and Hangtags are being used.

NOTE: correct positioning of this tag at the bottom of the rear-view mirror post will not inhibit the driver's view of the highway. Some car manufacturers will place a "window" in this area of the windshield (no tint or metal) for the express purpose of mounting toll and AVI tags like the WS421.

Prior to mounting the mounting area must be clean and free of oils or cleaning solutions. **Do Not Attempt** to remove this sticker once it is applied, you are very

likely to compromise the antenna which will render the tag useless. It is preferable to have a crooked tag than to destroy it.

Metallic Windshield Content – some vehicle manufacturers install windshields that contain a significant metal content in them. These are usually higher-end vehicles, though the practice varies widely and can often be found in a few domestic vehicles. When a windshield contains too much metal content, the passive UHF tags will not work – this is not limited to any one manufacturer, this is simple physics. See the suggestions below please.

VIPER – Multi-Surface Tag

The VIPER tag is well-suited for use on highly detuning and difficult-to-tag materials. This tag Meets the Challenges of Narrow Spaces and De-Tuning Materials. This tag is a good alternate when you encounter **metallic windshields**.



STEALTH – Multi-Surface Tag



The STEALTH is another multi-surface tag that is pre-tuned for metal and can be mounted on almost any surface. Since it is tuned for metal, the STEALTH works best when it is mounted on a metal surface. Most users use this tag for those tough to read vehicles and want a tag that can be hidden behind a plastic material.

NOTE: Make sure the reader is no lower than 5' from the earth's surface because the reader emits energy 4' from all its sides and the earth will absorb the signal giving you shorted read range.